

Metallic Systems

SPL Fitting Type C90



Technical Characteristics

Conforms to BSI Kitemark KM-35161
 UL514B file number E60625
 CE mark to the Low voltage directive

Approvals and Standards



Degree of mechanical protection Very High

Degree of protection IP67, IP68 & IP69k - with all [Adaptasteel](#) liquid tight conduit in the series

UV protection Very High

Fitting characteristics 90° combined fitting & elbow

Application For insertion into threaded entries & knockouts using a locknut

Normal operating temperature range	Application	Min Temp	Max Temp
	Static	- 65°C	+150°C
	Dynamic	- 45°C	+150°C

For use with - Conduit series Type [SPL](#), [SPL-EF](#), [SPLHC](#) & [SPUL](#)

Fire performance	Test Standard	Performance Rating
	Not Rated	Not Rated

Testing data [Click or see page 4](#)

Type of material Nickel Plated Brass , High temperature Co-Polyester seal - Nylon insert

Image



Metallic Systems

SPL Fitting Type C90



Dimensional Data

Part No	Thread A	Nominal Dimensions (mm)						
		B	C	D	E	F	G	H
SPL16/M16/C90	M16 x 1.5	16	48.0	49.3	22.0	25.4	10.4	13.1
SPL16/M20/C90	M20 x 1.5	16	48.0	50.9	22.0	25.4	10.5	13.1
SPL20/M20/C90	M20 x 1.5	20	53.7	57.2	27.0	28.6	14.0	14.3
SPL25/M25/C90	M25 x 1.5	25	63.7	66.4	33.0	35.0	18.2	16.6
SPL32/M32/C90	M32 x 1.5	32	74.4	79.9	42.0	42.0	24.1	17.6
SPL40/M40/C90	M40 x 1.5	40	88.4	94.3	51.0	52.0	32.0	17.6
SPL50/M50/C90	M50 x 1.5	50	99.8	108.5	60.0	60.0	37.7	20.5
SPL63/M63/C90	M63 x 1.5	63	120.9	129.7	74.0	70.0	48.4	23.1

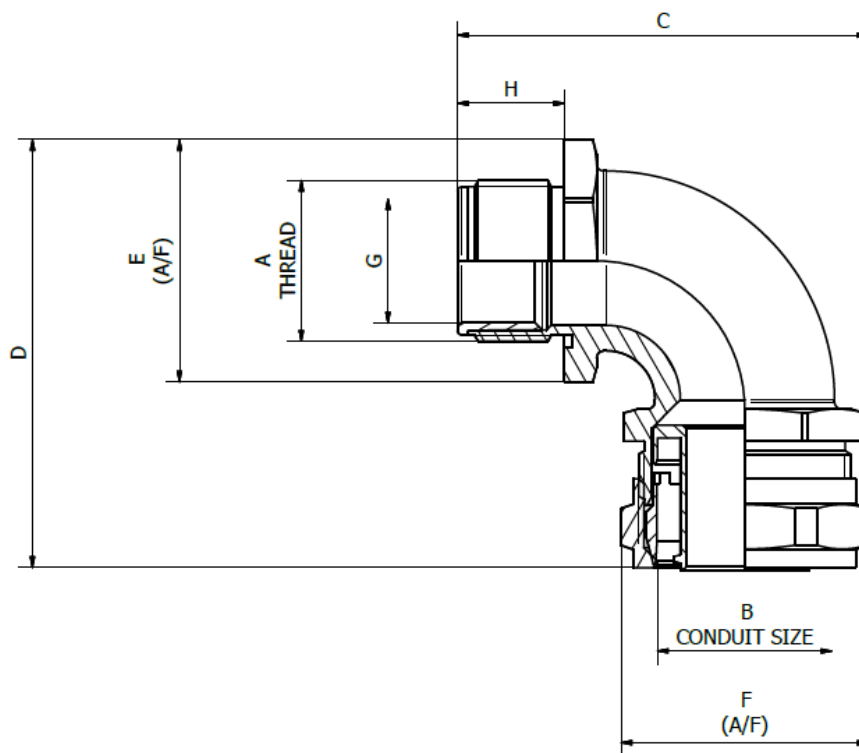

Metallic Systems

SPL Fitting Type C90



Dimensional Data

Part No	Thread A	Nominal Dimensions (mm)					
		B	C	D	E	F	G
SPL16/038/C90	3/8" NPT	16	48.0	48.3	22.0	25.4	10.4
SPL16/050/C90	1/2" NPT	16	48.0	48.3	22.0	25.4	10.5
SPL20/050/C90	1/2" NPT	20	53.7	54.7	27.0	28.6	14.0
SPL25/075/C90	3/4" NPT	25	63.8	65.3	33.0	35.0	18.2
SPL32/100/C90	1" NPT	32	74.4	82.9	42.0	42.0	24.1
SPL40/125/C90	1 1/4" NPT	40	88.4	94.7	51.0	52.0	32.7
SPL50/150/C90	1 1/2" NPT	50	98.8	106.1	60.0	60.0	37.7
SPL63/200/C90	2" NPT	63	120.9	130.2	74.0	70.0	48.4

All threads conform to ANSI/ASME B1.20.1—1983

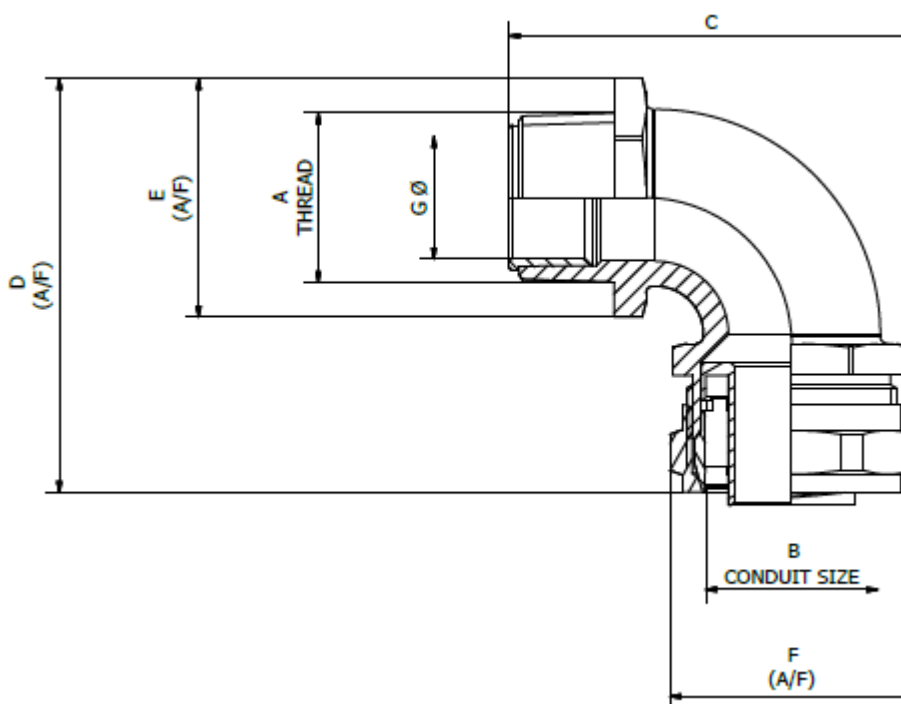

Metallic Systems

SPL Fitting Type C90



Chemical Resistance Chart

Key:

Suitable :



Limited Suitability :



Unsuitable :



Not Tested :



Astm No.1	Diesel oil	Methyl Bromide	Sulphur Dioxide (Gas)
Astm No.2	Diethylamine	MEK	Sulphuric Acid (10%)
Astm No.3	Ethanol	Nitric Acid (10%)	Sulphuric Acid (70%)
Acetic Acid (10%)	Ether	Nitric Acid (70%)	Toluene
Acetone	Ethylamine	Oxalic Acid	Transformer Oil
Aluminium Chloride	Ethylene Glycol	Ozone (Gas)	1,1,1-Trichloroethane
Aniline	Ethyl Ethanoate	Paraffin oil	Trichloroethylene
Benzaldehyde	Freon 32	Petrol	Turpentine
Benzene	Hydrochloric Acid (10%)	Phenol	Vegetable Oil
Carbon tetrachloride	Hydrochloric Acid (36%)	Sea Water	Vinyl Acetate
Chlorine water	Hydrogen Peroxide (35%)	Silver Nitrate	Water
Chloroform	Hydrogen Peroxide (87%)	Skydrol	White Spirit
Citric Acid	Lactic Acid	Sodium Chloride	Zinc Chloride
Copper Sulphate	Lubricating oil	Sodium Hydroxide (10%)	
Cresol	Methanol	Sodium Hydroxide (60%)	

The information above is given as a guide only and is based on published technical data and experience. The chemical resistance of the above products is dependant on factors such as chemical exposure, concentration of the chemical and temperature. The above chemicals are valid for a temperature of 23°C. Use of the above table is at the users own discretion and risk. Those using it must satisfy themselves that their application resents no health and safety risks. The end user should assess compatibility with their application and contact Thomas & Betts for further information.

ADHERENCE TO THE CURRENT WIRING REGULATIONS BS7671 OR NEC WIRING REGULATIONS (FOR USA) IS STRONGLY ADVISED.

MINIMUM BEND RADIUS FOR FLEXING IS DEPENDANT UPON MINIMUM TEMPERATURE, BENDING FREQUENCY AND CHEMICAL ENVIRONMENT.